

Many homes lose a great deal of energy efficiency through the basement. In fact, it's common to lose up to 30 percent of a home's heat in the basement. That loss causes the home's heating and cooling equipment to work much harder. It also can contribute significantly to higher utility bills. Here are three key suggestions for improving the basement's energy efficiency.

Seal the Band Joist

One of the most effective steps you can take is to seal the band joist in your basement. The band joist is the wooden beam just above your home's foundation. It sits atop the entire perimeter of the poured concrete or concrete-block foundation. It's the major beam that all the first floor joists are connected with.

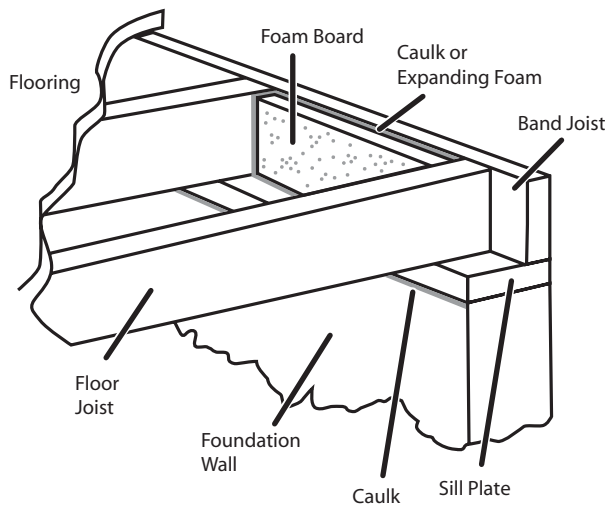

Cut 1- or 2-inch-thick foam board pieces to a rectangular size and insert between the floor joists, just above the foundation. Make sure the pieces fit snug against the joists on the left and right, and from the top of the foundation to the flooring. The edges are then sealed on all four sides with a bead of caulk or expanding foam.

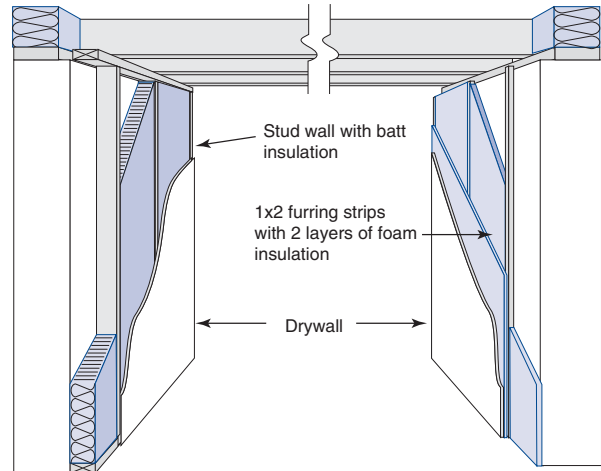

Insulate the Basement's Walls

Insulating your basement's walls can be more efficient than insulating its ceiling. An example of efficient heat retention is the common Styrofoam cup, which, while only 1/16 of an inch thick, protects skin against liquids in excess of 150 degrees Fahrenheit.

Insulating the walls will make even unconditioned basements significantly warmer in winter. This also places the ductwork in the thermal envelope of the home, again increasing efficiency.

There are several options to insulate these walls. One way is to build stud frames around the wall and add batt insulation. This is then covered with drywall.

OVER

Another option is to glue sheets of foam board (Thermax) directly to the walls without adding studs.

A third option is to have Icynene foam sprayed on the basement walls, which effectively seals all gaps and crevices in one step.

Seal the Ductwork

When ductwork leakage is reduced substantially, it makes an immediate improvement in air circulation throughout the house. If the ductwork is accessible, sealing it is a relatively simple procedure.

This is accomplished by applying a substance called mastic with a brush to every duct seam, with special attention paid to the return side of the system.

Mastic is a gray paste-like substance containing fiber, which is easily spread across the seams of the ductwork. It dries to a solid, cement-

like quality, providing a permanent solution to unwanted leakage on both the return and supply side of the ductwork.

Mastic can be purchased at companies that sell wholesale supplies to heating, ventilation and air conditioning contractors.

Once the leaks are fixed with mastic, more savings can be realized by insulating the ducts located in unheated areas with foil-faced fiberglass duct insulation or foil-faced “bubble wrap.” The insulation is simply wrapped around the duct and tied or taped into place.

If the ducts are inaccessible, a contractor may need to be hired to conduct a pressure test with a special fan. This “blower door” test can determine if there is serious leakage. Some duct connections may simply have come apart.

In most cases, a little time spent addressing this issue can make a major difference in the efficiency and longevity of the heating and air conditioning system.

Each home is unique, but most homeowners can realize great gains in energy efficiency by sealing the band joist, insulating the basement walls and sealing the holes in the ductwork.

